Corrosive Environment Pressure Transmitter

Model : P617 (Circular Connector)

WISE
SENSOR

Advantages

- Pressure transmitter for highly corrosive environments
- Extremely corrosion resistant ceramic diaphragm (Al₂O₃ 96%)
- Measuring ranges from 5000mmH₂O to 20kgf/cm² relative or absolute pressure
- Rugged piezoresistive or capacitive ceramic measuring cell
- Shock and vibration resistant
- Wetted part and housing of teflon
- Compact design

Applications

This transmitter is specially designed for a highly corrosive environmental condition where stainless steel could not be applied such as...

- Process control and monitoring in corrosive environment
- Chemical and petrochemical industry
- Corrosive liquid level measurement
- Plating and dyeing process controls



P617

Descriptions

P600 series pressure transmitter has been designed as an advanced device for measuring pressure of corrosive gases and liquids in industrial applications. It is extremely versatile and suitable for measuring static pressure.

The built-in ceramic measuring cell is highly corrosion resistant, stable and has an excellent price / performance ratio. Thanks to their high natural frequency and the rugged construction, the P600 transmitter withstands high shock and vibration. The transmitters are available as absolute and relative pressure types with either 2-wire current or 3-wire voltage output.

The pressure to be measured acts without transmitting liquid on a stable, corrosion resistant ceramic measuring cell. Piezoresistive resistors are attached to the cell and connected into a Wheatstone bridge configuration.

The output signal of this bridge is converted into a standardized current or voltage output signal.

Specification

Input				
Technology	Piezoresistive ceramic pressure sensor			
Pressure ranges	0~0.5 to 0~20 kgf/cm ² relative			
	0~1 to 0~20 kgf/cm ² absolute			
Pressure reference	Gauge, absolute, vacuum and compound			
Overload	1.5x full scale without damage			
Output				
	Current output		Voltage output	
Electrical connection type	2-wire technique		3 or 4-wire technique	
Full scale output signal	20mA	±0.5%	5V	±0.5%
Zero measured output	4mA	±0.05%	1V	±0.05%
	Other signals available on request			
Electrical Specification				
Excitation voltage	24V DC(12~36V DC)			
Load resistance max @ 24V	500Ω at 24V			
Influence of excitation	0.01% FSO/V			
Power ripple	≤500mV P-P			
Reverse polarity	Protected			
Shock resistance	≤20g			
Response time(10~90%)	1.5ms			
Performance Specification				
Accuracy	≤ ±0.5% FSO			
Linearity, Hysteresis & Repeatability	±0.2% FSO typical			
Stability	±0.3% FSO/a @25°C			
Cutoff frequency(-3 d B)	≤ 2KHz			
Reference temperature	25°C			
Operating temperature range	0~60°C			
Storage temperature range	-20~70°C			
Thermal sensitivity shift	≤ ±0.015%/°C typical			
Thermal zero shift	≤ ±0.02% FSO/°C typical			
Long term stability	≤ ±0.03% FSO over 6 months			
Physical Specification				
Process connection	PT1/2 male thread (standard)			
	Female thread & other connections available on request			
Process media	Gases and liquids compatible with ceramic Al ₂ O ₃ , 96%			
Materials	Diaphragm : Ceramic Al ₂ O ₃ , 96%			
	Housing and process connection : PTFE			
	Gasket O-ring : PTFE (Kalez, HNBR, CSM, etc.)			
Enclosure rating	IP65			
Influence of mounting position	Not critical			
Weight	Approx. (250g)			
Option	Siphon tube			

- Note :
- ① Cable version : 1.5m standard length, 4-wire, shielded with integral vent tube
 - ② Vented gauge units must breathe dry, non - corrosive gases.
 - ③ Connector version is vented through the removed pin, cable versions are vented through a vent tube inside the cable sleeve

System connection for 2-wire transmitter **System connection for 3-wire transmitter**

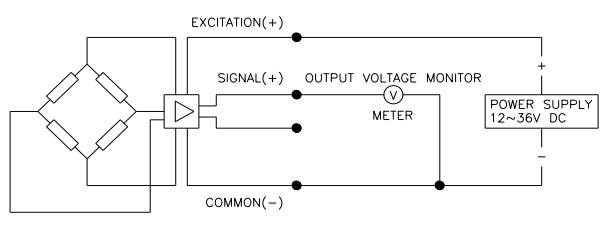
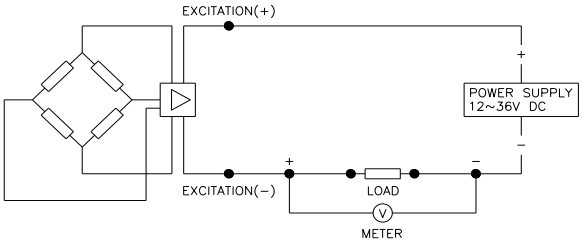

Dimension (mm) **Electrical connection**

- Wiring diagrams

E : Excitation

S : Signal

C : Common

System Conn.	Wire		
	2	3	4
Red	E +	E +	E +
Black	E -	C -	E -
Green		S +	S +
White			S -
GND	Shielded	Shielded	Shielded

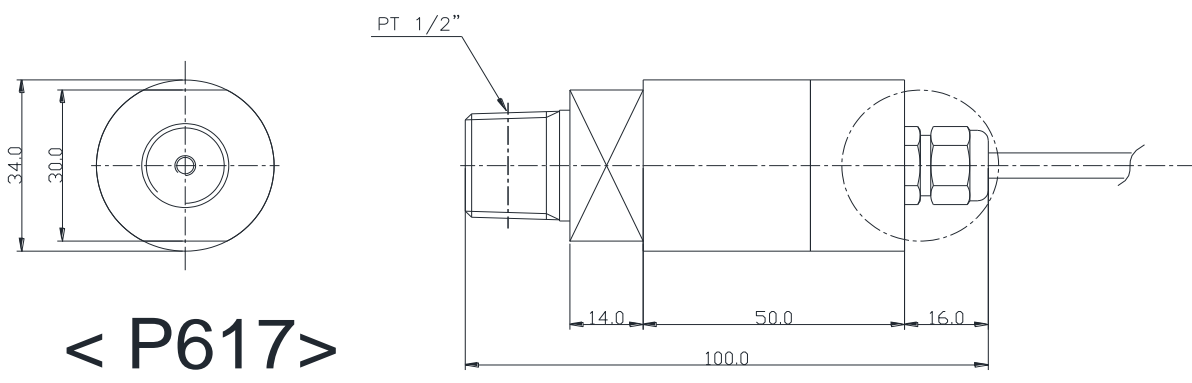

Ordering Information

Corrosive Environment Pressure Transmitter

1. Base model

P617											Flying lead(1.5m cable)
------	--	--	--	--	--	--	--	--	--	--	-------------------------

2. Pressure reference

R											Relative pressure
A											Absolute pressure

3. Process connection type "1"

M											Male thread
F											Female thread

4. Process connection type "2"

T											PT thread as standard
N											NPT thread
F											PF thread
X											Other process connections available on request

5. Process connection size

1											1/2"
X											Other units available on request

6. Accuracy

S											±0.5% F.S.O
---	--	--	--	--	--	--	--	--	--	--	-------------

7. Measuring range

01											0 ~ 0.5 kg/cm ²
02											0 ~ 1
03											0 ~ 2
04											0 ~ 5
05											0 ~ 10
06											0 ~ 20
xx											Other calibration ranges available on request

8. Unit

K											Calibration in kgf/cm ²
A											Calibration in Mpa
B											Calibration in bar
P											Calibration in psi
X											Other units available on request

9. Output signal / Electrical connection type

A1											4~20mA DC, 2-wire output
A2											4~20mA DC, 4-wire output
B1											1~5V DC, 3-wire output
XX											Other output signal available on request

10. Option

N											None options
S											Siphon tube
X											Other accessories available on request

P617	R	M	T	1	S	02	B	A1	N	Sample ordering code	
------	---	---	---	---	---	----	---	----	---	----------------------	--

Specifications subject to change without notice